

**Matrox**



# Meteor-II/Multi-Channel

**Low-cost frame grabber for monochrome or component RGB interlaced or progressive scan video acquisition.**



## Matrox Meteor-II/Multi-Channel

Matrox Meteor-II/Multi-Channel is part of the Matrox Meteor-II family of high performance frame grabbers for cost sensitive applications. Designed to capture from standard or variable analog monochrome or component RGB frame scan sources, it specifically supports acquisition from interlaced or progressive scan component RGB cameras and single or dual-channel progressive scan monochrome cameras. Matrox Meteor-II/Multi-Channel combines extensive functionality with unprecedented value in a frame grabber. OEMs and integrators use this technology to build powerful, yet cost-effective PC-based imaging systems.

### VIA: At the heart of the Matrox Meteor-II family

Common to all Matrox Meteor-II boards is the custom-designed Matrox Video Interface ASIC (VIA). It is a sophisticated memory controller for managing real-time acquisition into on-board memory with advanced reformatting capabilities and, in parallel, streaming image data out over the PCI bus without requiring constant host CPU intervention.

### Real-time capture to system or display

Matrox Meteor-II/Multi-Channel can transfer acquired images to either system (host CPU) memory for processing or display (VGA) memory for live video-in-a-window at sustained rates up to 130 MB/second.

## Key features

- PCI, CompactPCI® or PC/104-Plus™ form factor
- captures from interlaced or progressive scan component RGB and single or dual channel monochrome analog video sources
- sampling rates up to 30 MHz
- three 256 x 8-bit LUTs
- connect two RGB or up to six monochrome video sources
- trigger input and timer outputs
- 32-bit / 33 MHz PCI bus-master
- real-time transfer to system or VGA memory
- extensive on-board buffering for reliable capture
- support for packed or planar transfers of color or multiple monochrome streams
- power output<sup>1</sup> and RS-232 serial interface<sup>2</sup>
- available software is sold separately and includes Matrox Imaging Library (MIL)/ActiveMIL, MIL-Lite/ActiveMIL-Lite and Matrox Inspector
- support for Microsoft® Windows® 98, Windows® Me, Windows NT® 4.0, Windows® 2000 and Windows® XP

## Matrox Meteor-II/Multi-Channel

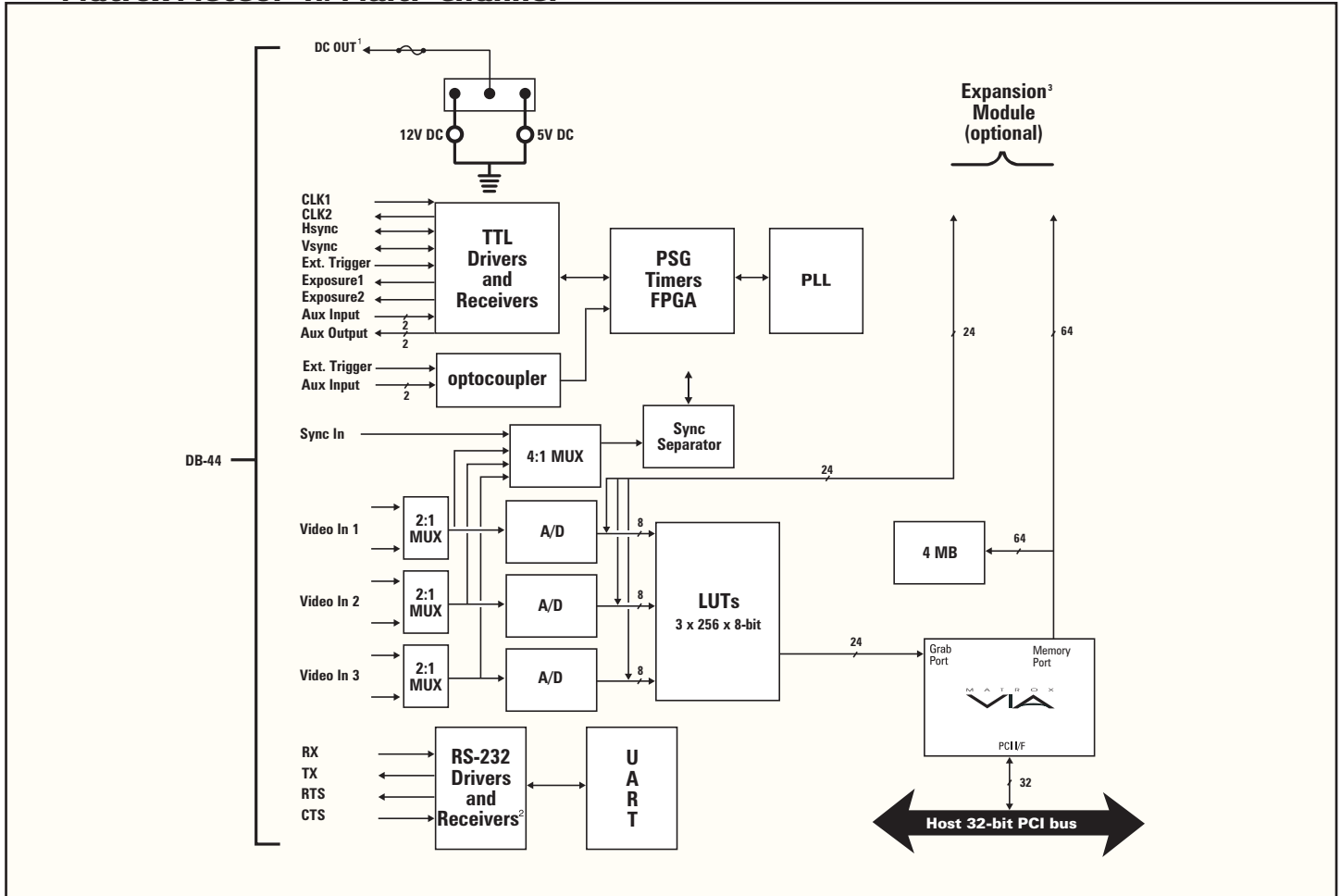

### Image formatting

Image data can be reformatted by Matrox VIA in real-time prior to transfer to host system or display. Features of Matrox VIA include cropping (ROI capture), independent horizontal and vertical sub-sampling from 2 to 16 (by decimation).

Matrox VIA can also perform reformatting operations specifically designed for reconstructing images from multi-tap cameras in real-time. Image data presented simultaneously in either odd/even pixel, odd/even line, opposite scan segments or a combination, can be re-ordered into a proper image with little or no host CPU involvement.

### Power output<sup>1</sup>

Matrox Meteor-II/Multi-Channel can supply 5 or 12V<sup>4</sup> DC power to cameras. Power is taken directly from the PC power supply, preventing any overload to the PCI bus<sup>5</sup>.

### RS-232 serial interface<sup>2</sup>

Matrox Meteor-II/Multi-Channel features an RS-232 serial interface to enable remote programming of a camera (i.e., gain, gamma control, operation mode), motion control unit or PLC.

### PCI interface

Matrox Meteor-II/Multi-Channel features a 32-bit PCI bus master/slave host interface. The bus master mode performs transfers without requiring continuous host intervention at rates up to 130 MB/second sustained.

Extensive buffering ensures reliable real-time transfer of incoming image data to host memory even under high bus latency conditions, which typically occurs in systems with concurrent image capture, display, graphics, network access, disk access and general external I/O. The PCI interface supports image data sub-sampling from 2 to 16 (by decimation) to further reduce required PCI bus bandwidth.

The PCI interface also supports packed or planar transfers of color or multiple monochrome streams. Acquisition-related events such as start and end of frame, and field or sequence capture can be routed to the host CPU as interrupts to optimize concurrent acquisition and processing (double-buffering).

## Software

Software support is available for Microsoft® Windows® 98, Windows® Me, Windows NT® 4.0, Windows® 2000 and Windows® XP, and consists of Matrox Imaging Library (MIL)/ ActiveMIL or MIL-Lite/ActiveMIL-Lite development toolkits for creating custom applications. Matrox Meteor-II/Multi-Channel is also supported by Matrox Inspector Windows®-based interactive imaging software.

## Specifications

### Acquisition

- three-channel analog variable frame scan
- monochrome or RGB interlaced or progressive scan
- sampling rate up to 30 MHz
- SNR of 47 dB
- pixel jitter of  $\pm 1.5$  ns
- variable gain amplifier
- 10 MHz input low pass filter
- adjustable ADC references
- three 256 x 8-bit programmable LUTs
- separate TTL pclk (in and out), hsync (in or out), vsync (in or out) and two timer (exposure) outputs
- two opto-isolated differential auxiliary inputs and two TTL auxiliary inputs and outputs
- opto-isolated differential and TTL trigger inputs (synchronous and asynchronous to video)
- connect and switch between 2 RGB or up to 6 monochrome sources

### Formatting

- input cropping (ROI capture)
- independent horizontal and vertical sub-sampling from 2 to 16 (by decimation)

### RS-232 interface<sup>2</sup>

- supports RX, TX, RTS and CTS signals
- not visible to OS (controlled through MIL API)

### Power output<sup>1</sup>:

- 5 or 12V<sup>4</sup> DC at 3A
- from PC power supply (not PCI slot)<sup>5</sup>

### Host interface

- 32-bit PCI bus master/slave
- up to 130 MB/second sustained
- 4 MB SGRAM buffer for PCI and PC/104-*Plus*<sup>TM</sup> and 4 MB SDRAM for CompactPCI<sup>TM</sup>
- support for packed or planar image data formats
- independent horizontal and vertical sub-sampling both from 2 to 16 (by decimation)
- interrupts for start and end of field, frame and sequence capture
- universal 32-bit card edge connector

### Connector pinouts

To see connector pinout diagrams for the Matrox Meteor-II/ Multi-Channel, please visit the product section of the Matrox Imaging web site: [http://www.matrox.com/imaging/products/meteor\\_2\\_mc](http://www.matrox.com/imaging/products/meteor_2_mc)

### Dimensions and environmental information

- PCI version<sup>6</sup>:
  - 20.3 L x 10.67 H cm (8" x 4.2")
- 3U CompactPCI<sup>®</sup> version<sup>7</sup>:
  - 16 L x 10 H cm (6.3" x 3.9")
- PC/104-*Plus*<sup>TM</sup> version<sup>8</sup>:
  - 11.56 L x 9.6 H cm (4.55" x 3.78")
- operating temperature: 0° C to 55° C (32° F to 131° F)
- relative humidity: up to 95% (non-condensing)
- FCC class A
- CE class A

### Software Environment

- drivers for Microsoft® Windows® 98, Me, NT® 4.0, 2000 and XP
- programmed using DLL interface (MIL/MIL-Lite) with Microsoft® Visual C++<sup>®</sup>
- programmed using ActiveX (OCX) interface (ActiveMIL/ ActiveMIL-Lite) with Microsoft® Visual Basic<sup>®</sup> or C++<sup>®</sup>
- support for multiple boards

## Ordering Information

Part number	Description
<b>Hardware</b>	
METEOR2-MC/4 (PCI)	Standard/non-standard
MET2-C-MC (CompactPCI®)	analog RGB/monochrome frame grabber.
MET2-MC+/4 (PC/104-Plus™)	

## Bulk Packaging/Bundles

M2-MC/4B	20 x METEOR2-MC/4
M2-MC/4+G2P/8B	20 x METEOR2-MC/4 with Millennium G200 for PCI (G2+/MSDP/8N)

Ordered separately:

## Software

MIL LITE 7	MIL-Lite board control library (see MIL-Lite brochure for more details).
MIL 7 DEV P or U	Matrox Imaging Library (MIL) (see MIL brochure for more details).
INSPECTOR 4 P or U	Matrox Inspector Interactive Windows® imaging software (see Inspector brochure for more details).

## Input cables

DBHD44-TO-8BNC	2.13 m (7') input cable, high density DB-44 to eight BNCs.
DH44-TO-8BNC/0	1.82 m (6') input cable, high density DB-44 to eight BNCs and open end (to access sync. and control signals).

## Notes:

1. Power output not available on PC/104-Plus™ version.
2. RS-232 interface not present on PC/104-Plus™ version.
3. Expansion module not supported on CompactPCI version.
4. 12V DC not available on CompactPCI version.
5. Taken from CompactPCI slot for CompactPCI version.
6. Vertical dimensions are from bottom edge of goldfinger to top edge of board. Horizontal dimensions are from edges of board excluding bracket.
7. Vertical and horizontal dimensions are from edges of board excluding bracket and connector.
8. Vertical and horizontal dimensions are from edges of board.

# matrox

For more information, please call: 1-800-804-6243 (toll free in North America) or (514) 822-6020  
or e-mail: [imaging.info@matrox.com](mailto:imaging.info@matrox.com) or <http://www.matrox.com/imaging>

### Corporate headquarters:

Canada and U.S.A.  
Matrox Electronic Systems Ltd.  
1055 St. Regis Blvd.  
Dorval, Quebec H9P 2T4  
Canada  
Tel: (514) 685-2630  
Fax: (514) 822-6273

### Offices:

Europe, Middle East & Africa  
Matrox VITE Limited  
Sefton Park  
Stoke Poges  
Buckinghamshire  
SL2 4JS  
UK  
Tel: 01753 665511  
Fax: 01753 665599

France  
Matrox France SARL  
2, rue de la Couture  
Silic 225  
94528 Rungis Cedex  
Tel: (0) 1 45-60-62-00  
Fax: (0) 1 45-60-62-05

Germany  
Matrox Electronic Systems GmbH  
Inselkammerstr. 8  
D-82008 Unterhaching  
Tel: 089/62170-0  
Fax: 089/614 9743

All trademarks by their respective owners are hereby acknowledged. Matrox Electronic Systems, Ltd. reserves the right to make changes in specifications at any time and without notice. The information furnished by Matrox Electronic Systems, Ltd. is believed to be accurate and reliable. However, no responsibility license is granted under any patents or patent rights of Matrox Electronic Systems, Ltd. Windows and Microsoft are trademarks of Microsoft Corporation. MMX and the MMX logo are registered trademarks of Intel Corporation. Printed in Canada, 22-07-2002. **51E-5151-B**